

# Dedicated I/O Modules

## ■ SUMMARY OF MODULES AVAILABLE

Name	Model	Specifications	
Analog I/O modules	CQM1-AD042	Analog inputs: 4 points, built-in power supply -10 to + 10 V, 0 to 10 V, 0 to 5 V, or 0 to 20 mA	
	CQM1-AD041	Analog inputs: 4 points, order separate power supply -10 to + 10 V, 0 to 10 V, 1 to 5 V, or 0 to 20 mA	
	CQM1-DA022	Analog outputs: 2 points, built-in power supply -10 to +10 V or 0 to 20 mA	
	CQM1-DA021	Analog outputs: 2 points, order separate power supply -10 to +10 V or 0 to 20 mA	
	CQM1-IPS01	Power Supply Module required for AD041 and DA021 modules	For one Analog module
	CQM1-IPS02		For two Analog modules
B7A Link master modules	CQM1-B7A02	16 outputs	
	CQM1-B7A12	16 inputs	
	CQM1-B7A03	32 outputs	
	CQM1-B7A13	32 inputs	
	CQM1-B7A21	16 inputs and 16 outputs	
	B7A Link slave modules	B7A-□6□, B7AS-R6□	16-point transistor inputs and outputs
G70D-R6□-B7A		16-point relay outputs	
B7AM-6□, B7AM-8o		Mixed I/O with 16 inputs/16 outputs or 8 inputs/8 outputs	
B7A-□10□, B7AC-T10		10-point transistor inputs and outputs, 10-point sealed input link	
Temperature controller modules		CQM1-TC001	Thermocouple input (types J and K), transistor (NPN) output, 2 loops
	CQM1-TC002	Thermocouple input (types J and K), transistor (PNP) output, 2 loops	
	CQM1-TC101	Platinum resistance thermometer input (Pt and JPt), transistor (NPN) output, 2 loops	
	CQM1-TC102	Platinum resistance thermometer input, transistor (PNP) output, 2 loops	
	CQM1-TC201	Thermocouple input, transistor (NPN) output, 4 loops	
	CQM1-TC202	Thermocouple input, transistor (PNP) output, 4 loops	
	CQM1-TC203	Thermocouple input, transistor (NPN) output, 2 loops (with heater burn-out alarm)	
	CQM1-TC204	Thermocouple input, transistor (PNP) output, 2 loops (with heater burn-out alarm)	
	CQM1-TC301	Platinum resistance thermometer input, transistor (NPN) output, 4 loops	
	CQM1-TC302	Platinum resistance thermometer input, transistor (PNP) output, 4 loops	
	CQM1-TC303	Platinum resistance thermometer input, transistor (NPN) output, 2 loops (with heater burnout alarm)	
	CQM1-TC304	Platinum resistance thermometer input, transistor (PNP) output, 2 loops (with heater burnout alarm)	
	Linear sensor interface modules	CQM1-LSE01	Measure voltage or current inputs from linear sensors and convert the measurements to numeric data for comparative decision processing. Standard type.
		CQM1-LSE02	Module with monitor output: -9.999 V to +9.999 V
Safety relay module	CQM1-SF200	Emergency stop unit: 2 inputs/2 outputs, 4 general-purpose inputs	

## Analog Input and Output Modules

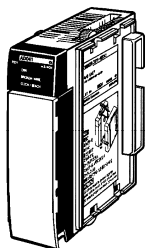

**CQM1-AD042**  
Analog Input Module with  
built-in power supply

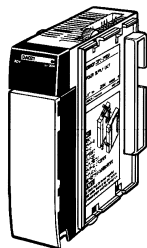

**CQM1-DA022**  
Analog Output Module  
with built-in power supply

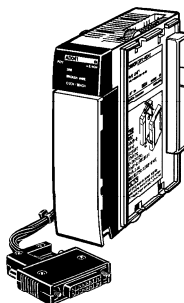

**CQM1-AD041**  
Analog Input Module, use  
separate power supply

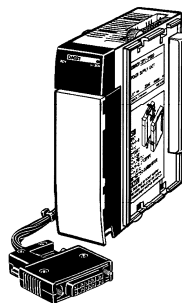

**CQM1-DA021**  
Analog Output Module, use  
separate power supply

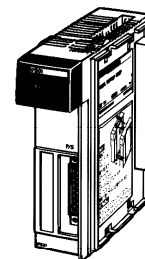

**CQM1-IPS01/IPS02**  
Power Supply Modules

## ■ SPECIFICATIONS

### Analog I/O Modules

Module type		Analog input		Analog output	
Model number		CQM1-AD042	CQM1-AD041	CQM1-DA022	CQM1-DA021
I/O points		4	4 or 2, selectable	2	2
Ranges		-10 V to +10 V 0 V to 10 V 0 V to 5 V 0 mA to 20 mA	-10 to +10 V 0 V to 10 V 1 V to 5 V 4 mA to 20 mA	-10 V to +10 V 0 mA to 20 mA	-10 V to +10 V 0 mA to 20 mA
Resolution	Voltage	12 bit binary (1/4096)	12 bit binary (1/4000)	12 bit binary (1/4096)	12 bit binary (1/4096)
	Current	12 bit binary (1/4096)	12 bit binary (1/4000)	11 bit binary (1/2048)	11 bit binary (1/2048)
Accuracy	At 25°C	±0.5% of FS	—	±0.5% of FS	—
	0°C to 55°C	±1.0% of FS	±1.0% of FS	±1.0% of FS	±1.0% of FS
Conversion speed		1.2 ms/point	2.5 ms/point	5 ms/2 points	5 ms/2 points
Input impedance	Voltage	1 MΩ min.	1 MΩ min.	—	—
	Current	250 Ω	250 Ω	—	—
External output load resistance	Voltage	—	—	1 kΩ min.	2 kΩ min.
	Current	—	—	520 Ω max. including wiring impedance	350 Ω max.
Power supply		Built-in, DC/DC converter	External, use CQM1-IPS01 or IPS02	Built-in, DC/DC converter	External, use CQM1-IPS01 or IPS02
Current consumption		170 mA at 5 VDC	80 mA max. at 5 VDC	340 mA at 5 VDC	90 mA at 5 VDC

### Power Supply Modules

Model number	CQM1-IPS01	CQM1-IPS02
Number of analog modules supported	One CQM1-AD041 or one CQM1-DA021	Two CQM1-AD041; one CQM1-AD041 and one CQM1-DA021
Current consumption (add to current consumption for analog module)	420 mA max. at 5 VDC	950 mA max. at 5 VDC

Note: To power two CQM1-DA021 analog output modules, use two CQM1-IPS01 power supply modules.

■ SYSTEM CONFIGURATION

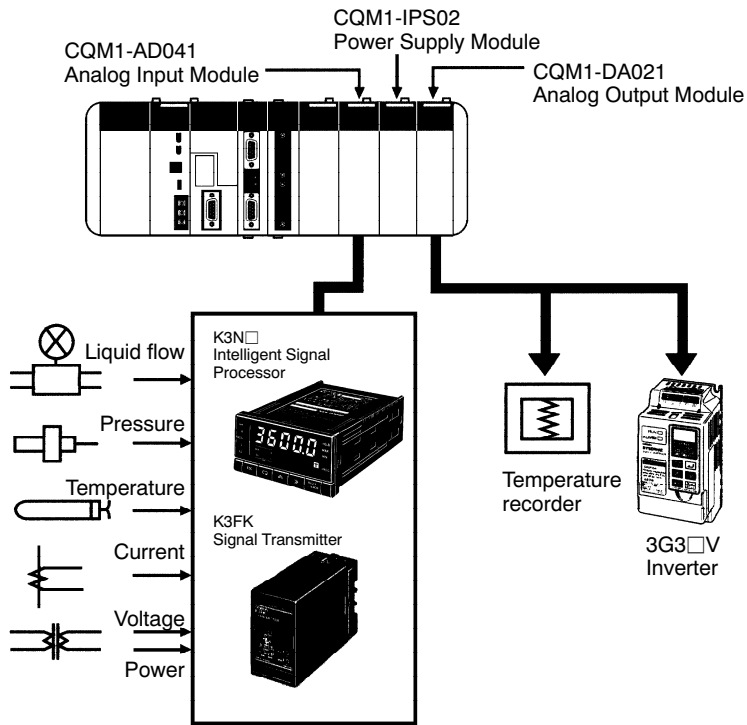

## B7A Link Interface Modules

A wire-saving B7A Link for remote I/O consists of master modules mounted to the PLC and remote terminal blocks connected to I/O devices. The terminal blocks can be located up to 500 m away using a single cable.

CQM1-B7A□□



- Just two wires transmit data, simplifies installation and troubleshooting
- High-speed (100 m max. at 3 ms) and long distance (500 m max. at 19.2 ms) configurations available
- Wide range of transistor and relay blocks to meet application needs
- Transmission distance up to 500 m
- Master acts like a high-density I/O module connecting 16 or 32 points to the controller with just two or three wires
- Supports 16-point input, output, mixed I/O and 10-point B7A terminal blocks and printed circuit board modules
- Output modules offer Hold and Load OFF handling of transmission errors

### ■ B7A LINK MASTER MODULES

I/O classification	Model	Transmission capabilities
16-point output	CQM1-B7A02	Long distance (19.2 ms) and high-speed (3 ms) systems, selectable
32-point output	CQM1-B7A03	
16-point input	CQM1-B7A12	
32-point input	CQM1-B7A13	
16-point input/16-point output	CQM1-B7A21	

### ■ SPECIFICATIONS

Item	CQM1-B7A21	CQM1-B7A13	CQM1-B7A03	CQM1-B7A12	CQM1-B7A02
No. of I/O points	16 inputs, 16 outputs (See Note 1)	32 inputs (See Note 2)	32 outputs	16 inputs (See Note 1)	16 outputs
Transmission method	Single-direction, time-division multiplex				
Transmission distance	Long distance: 500 m max. or 100 m max. High-speed: 100 m max. or 50 m max. (See Note 3)				
Transmission speed	Normal: 19.2 ms (typical); 31 ms max. High-speed: 3 ms (typical); 5 ms max.				
I/O word allocation (See Note 4)	1 word each for input and output (2 words total)	2 words for input	2 words for output	1 word for input	1 word for output
Required power supply	0.11 A min.	0.07 A min.	0.10 A min.	0.05 A min.	0.04 A min.
Current consumption (module as part of CQM1)	100 mA max., 5 VDC				

- Note: 1. Input mode setting allows selection between 16-point input and 15-point input + 1 error input.  
 2. Input mode setting allows selection between 32-point input and 30-point input + 2 error inputs.  
 3. The transmission distance varies with the transmission speed and depends on where power is applied:  
For normal speed setting:  
 If B7A Master Link and the B7A input and output modules each have power supplies, the transmission distance is 500 m. If one power supply is attached, the transmission distance is 100 m.  
For high-speed setting:  
 If B7A Master Link and the B7A input and output modules each have power supplies, the transmission distance is 100 m. If one power supply is attached, the transmission distance is 50 m.  
 4. For addressing, words are allocated in sequence according to the location of the B7A Master on the PLC, as with other CQM1 I/O modules.

For more details on the B7A Master Link Interface Modules, refer to the CQM1 *Dedicated I/O Modules Operation Manual* (W238).

■ B7A LINK SLAVES

16-point Terminals

Transistor I/O Link Modules

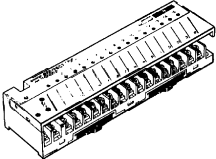
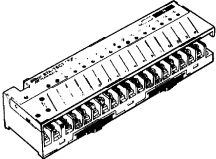
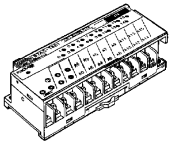
Appearance	I/O classification	I/O configuration	I/O delay (typical)	Internal I/O common	Error processing (See Note 1)	Part number	
	Input, 16 points	NPN compatible	Normal speed 19.2 ms	- common	—	<b>B7A-T6A1</b> (See Note 2)	
				+/- common	—	<b>B7A-T6B1</b> (See Note 2)	
		PNP compatible		+/- common	—	<b>B7A-T6C1</b>	
		NPN compatible	High speed 3 ms	- common	—	<b>B7A-T6A6</b> (See Note 2)	
				+/- common	—	<b>B7A-T6B6</b> (See Note 2)	
		PNP compatible		+/- common	—	<b>B7A-T6C6</b>	
	Output, 16 points	NPN open collector 100 mA/point	Normal speed 19.2 ms	+ common	HOLD	<b>B7A-R6B11</b>	
					LOAD OFF	<b>B7A-R6B31</b>	
		NPN open collector 500 mA/point (See Note 3)			HOLD	<b>B7A-R6C11</b>	
					LOAD OFF	<b>B7A-R6C31</b>	
		PNP open collector 100 mA/point	High speed 3 ms	- common	HOLD	<b>B7A-R6F11</b>	
					LOAD OFF	<b>B7A-R6F31</b>	
		PNP open collector 500 mA/point (See Note 4)			HOLD	<b>B7A-R6G11</b>	
					LOAD OFF	<b>B7A-R6G31</b>	
		NPN open collector 100 mA/point	High speed 3 ms	+ common	HOLD	<b>B7A-R6B16</b>	
					LOAD OFF	<b>B7A-R6B36</b>	
		NPN open collector 500 mA/point (See Note 3)			HOLD	<b>B7A-R6C16</b>	
					LOAD OFF	<b>B7A-R6C36</b>	
PNP open collector 100 mA/point	High speed 3 ms	- common	HOLD	<b>B7A-R6F16</b>			
			LOAD OFF	<b>B7A-R6F36</b>			
PNP open collector 500 mA/point (See Note 4)			HOLD	<b>B7A-R6G16</b>			
			LOAD OFF	<b>B7A-R6G36</b>			
	Input, 16 points	NPN compatible	Normal speed 19.2 ms	+/- common	—	<b>B7AS-T6B1</b>	
			High speed 3 ms		—	<b>B7AS-T6B6</b>	
	Output, 16 points	NPN open collector 100 mA/point	Normal speed 19.2 ms	HOLD		<b>B7AS-R6B11</b>	
				LOAD OFF		<b>B7AS-R6B31</b>	
				High speed 3 ms		HOLD	<b>B7AS-R6B16</b>
				LOAD OFF		<b>B7AS-R6B36</b>	

16-point Relay Output Link Modules

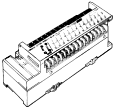
Appearance	I/O classification	I/O configuration	I/O delay (typical)	Error processing (See Note 1)	Part number
	Output, 16 points (SPST-NO)	Relay outputs G6D-1A DC24	Normal speed 19.2 ms (See Note 2)	HOLD	G70D-R6R11-B7A
				LOAD OFF	G70D-R6R31-B7A
		Power MOSFET relay outputs G3DZ-2R6PL DC24		HOLD	G70D-R6M11-B7A
				LOAD OFF	G70D-R6M31-B7A

- Note: 1. HOLD: The previous output condition will be on hold when an error occurs.  
LOAD OFF: All outputs will be OFF when an error occurs.
2. The 16-point B7A-T6A□ and 16-point B7A-T6B□ are different from each other in terminal configuration.
3. N-channel MOSFET open drain output
4. P-channel MOSFET open drain output

Link Master Adapters for High-density I/O Modules

Appearance	I/O classification	I/O configuration	I/O delay (typical)	Error processing (See Note 1)	Part number
	Input, 32 points Use with CQM1-OD213.	NPN compatible	Normal speed 19.2 ms	—	B7A-T3E3
			High speed 3 ms	—	B7A-T3E8
	Output, 32 points Use with CQM1-ID213.	NPN open collector 50 mA/point	Normal speed 19.2 ms	HOLD	B7A-R3A13
				LOAD OFF	B7A-R3A33
			High speed 3 ms	HOLD	B7A-R3A18
				LOAD OFF	B7A-R3A38

Mixed I/O Link Modules

Screw Terminal Models (with 8 Input and 8 Output Points)

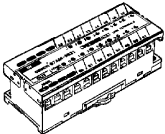
Appearance	I/O configuration	I/O delay (typical)	Error processing (See Note 1)	Part number
	NPN compatible/ NPN open collector 100 mA/point 8 input/8 output points	Normal speed 19.2 ms	HOLD	B7AM-8B11
			LOAD OFF	B7AM-8B31
		High speed 3 ms	HOLD	B7AM-8B16
			LOAD OFF	B7AM-8B36
	PNP compatible/ PNP open collector 100 mA/point 8 input/8 output points	Normal speed 19.2 ms	LOAD OFF	B7AM-8F31

Screw Terminal Model (with 16 Input and 16 Output Points)

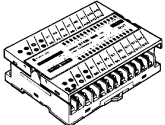

Appearance	I/O configuration	I/O delay (typical)	Error processing (See Note 1)	Part number
	NPN compatible/ NPN open collector 100 mA/point 16 input/16 output points	Normal speed 19.2 ms High speed 3 ms (switch selectable)	HOLD/ LOAD OFF (switch setting)	B7AM-6BS

10-point Terminal Models

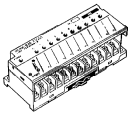
Transistor I/O Link Modules

Appearance	I/O classification	I/O configuration	Internal I/O common	Error processing (See Note 1)	Part number
	Input, 10 points (See Note 2)	NPN compatible (No two-wire sensor can be connected.)	- common	—	<b>B7A-T10S1</b>
			+/- common	—	<b>B7A-T10S3</b>
	Output, 10 points	NPN open collector 100 mA/point	+ common	HOLD	<b>B7A-R10SC01</b>

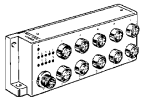
Sealed Input Module with M12 Connectors

Appearance	Description	I/O configuration	I/O delay (typical)	Enclosure rating	Part number
	B7A 10-point sealed input module; M12 connectors	NPN compatible	19.2 ms	IP67	<b>B7AC-T10A1</b>
	DeviceNet interface module connects up to 3 B7AC modules			IP66	<b>DRT1-B7AC</b>

- Note: 1. HOLD: The previous output condition will be on hold when an error results.  
 LOAD OFF: All outputs will be OFF when an error results.
2. The 10-point B7A-T10S1 and 10-point B7A-T10S3 are different from each other in terminal configuration.

■ SYSTEM CONFIGURATION

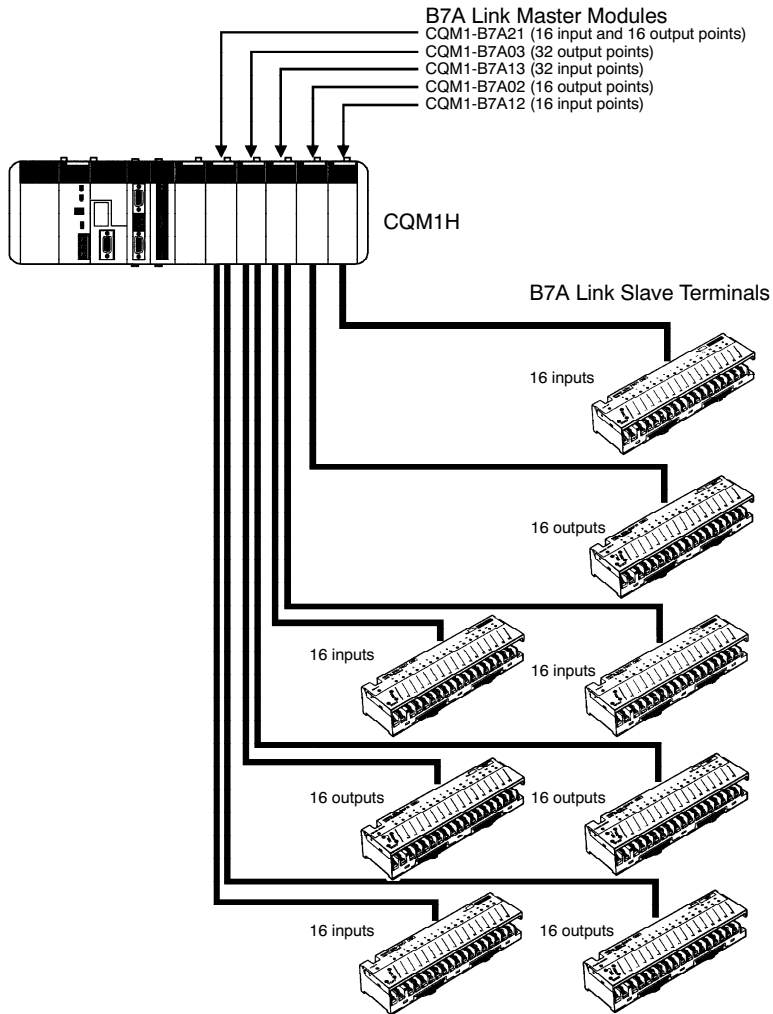

**CQM1 High-Density I/O Modules with B7A Link Master Adapters**

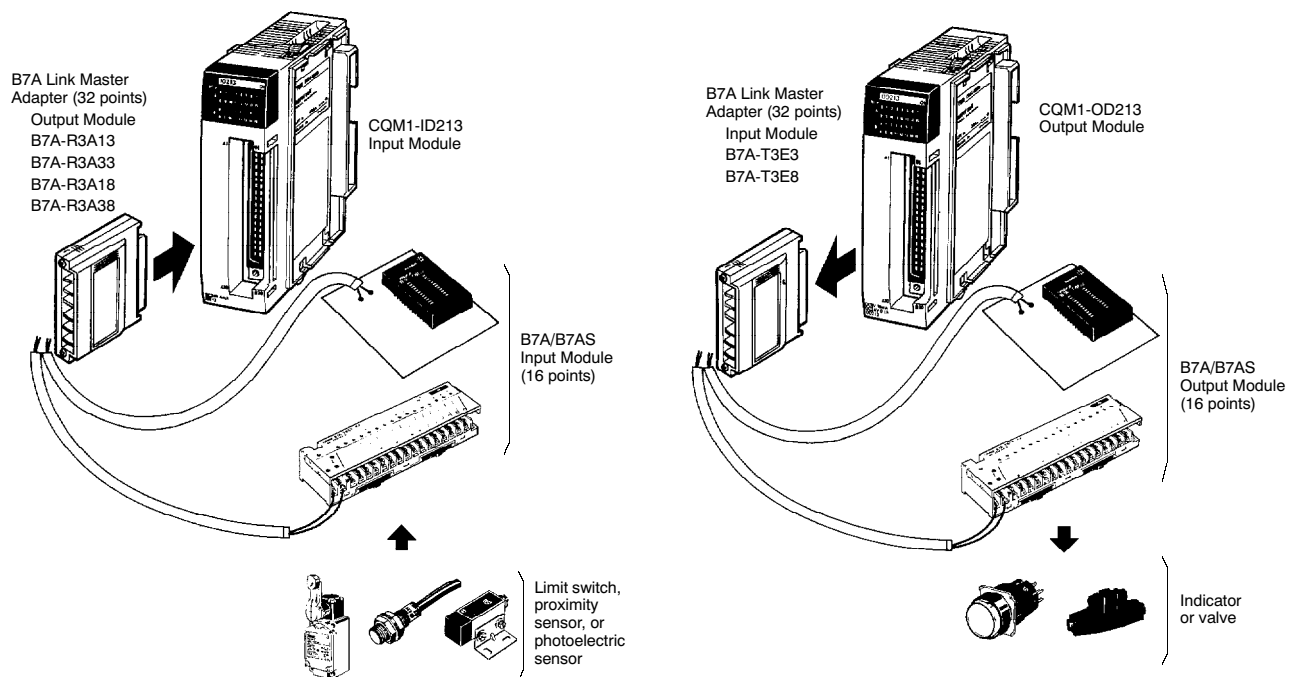

## Temperature Controller Modules

Omron offers Temperature Controller Modules for 4-loop temperature control, 2-loop temperature control, and 2-loop temperature control with heater burnout alarm.

Parameters can be set and data read for these Temperature Controllers by transferring commands from the PLC. With only one word each allocated to the Temperature Controller Module for inputs and outputs, high-density temperature control applications become economical. Commands can be transferred easily using the TRANSFER I/O COMMAND instruction that has been added to the CQM1H CPUs (See Note). The PID with advanced feed-forward circuitry assures stable temperature control. The controllers can also be set to ON/OFF control.

Note: Parameters can be set and data read for the TC20□ and TC30□ using the new IOTC(—) instruction. The IOTC instruction is supported by CQM1H CPUs with a lot number of 0160 or later and CX-Programmer support software version 2.0 or later.

**Thermocouple Inputs:**  
CQM1-TC00□/TC20□

**Platinum Resistance Thermometer Inputs:**  
CQM1-TC10□/TC30□

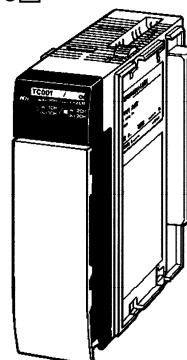

### ■ MODULES

Name	Model	Specifications
Temperature Controller Modules	CQM1-TC001	Thermocouple input (types J and K), transistor (NPN) output, 2 loops
	CQM1-TC002	Thermocouple input (types J and K), transistor (PNP) output, 2 loops
	CQM1-TC101	Platinum resistance thermometer input (Pt and JPt), transistor (NPN) output, 2 loops
	CQM1-TC102	Platinum resistance thermometer input, transistor (PNP) output, 2 loops
	CQM1-TC201	Thermocouple input, transistor (NPN) output, 4 loops
	CQM1-TC202	Thermocouple input, transistor (PNP) output, 4 loops
	CQM1-TC203	Thermocouple input, transistor (NPN) output, 2 loops (with heater burnout alarm)
	CQM1-TC204	Thermocouple input, transistor (PNP) output, 2 loops (with heater burnout alarm)
	CQM1-TC301	Platinum resistance thermometer input, transistor (NPN) output, 4 loops
	CQM1-TC302	Platinum resistance thermometer input, transistor (PNP) output, 4 loops
	CQM1-TC303	Platinum resistance thermometer input, transistor (NPN) output, 2 loops (with heater burnout alarm)
	CQM1-TC304	Platinum resistance thermometer input, transistor (PNP) output, 2 loops (with heater burnout alarm)
Current detectors for heater burnout alarm	E54-CT1	Measuring range of 0 to 30 A, 5.8 mm dia. hole
	E54-CT2	Measuring range of 0 to 50 A, 12 mm dia. hole

■ SPECIFICATIONS

Temperature Controller Modules

Model		CQM1-TC00□	CQM1-TC10□	CQM1-TC20□	CQM1-TC30□
Input	Input type	Thermocouple input	Platinum resistance thermometer input	Thermocouple input	Platinum resistance thermometer input
	Input sensor types and set point ranges	K: 200 to 1,300°C (-300 to 2,300°F) J: 100 to 850°C (-100 to 1,500°F)	JPt: -99.9 to 450.0°C (-99.9 to 800.0°F) Pt: -99.9 to 450.0°C (-99.9 to 800.0°F)	K, J, T, L, R, S, B (See the following table for temperature ranges.)	Pt, JPt (See the following table for temperature ranges.)
	Number of control loops	Two (either 1 or 2 loops can be used)		4 loops (TC□01 or TC□02) or 2 loops with heater burnout alarm (TC□03 or TC□04)	
Control mode		ON/OFF or advanced PID control		ON/OFF control, advanced PID control (2 degrees of freedom), or manual operation	
Setting and display accuracy		°C Ranges (Set point ±1% or ±3°C, whichever is larger) ±1 digit max. °F Ranges (Set point ±1% or ±6°F, whichever is larger) ±1 digit max.	°C Ranges (Set point ±1% or ±2°C, whichever is larger) ±1 digit max. °F Ranges (Set point ±1% or ±4°F, whichever is larger) ±1 digit max.	°C Ranges (Set point ±0.3% or ±1°C, whichever is larger) ±1 digit max. °F Ranges (Set point ±0.3% or ±2°F, whichever is larger) ±1 digit max.	0.1°C Ranges (Set point ±0.3% or ±0.8°C, whichever is larger) ±1 digit max. 0.1°F Ranges (Set point ±0.3% or ±1.6°F, whichever is larger) ±1 digit max. (See note 1.) 0.01°C Ranges (Set point ±0.3% or ±0.5°C, whichever is larger) ±1 digit max.
Temperature adjustment		0.8 °C/°F		0.1 to 999.9 °C/°F (0.1°C/°F unit)	
Proportional band		40.0 °C/°F		0.1 to 999.9 °C/°F (0.1°C/°F unit)	
Derivative time		240 s		0 to 3,999 s (1 s unit)	
Integral time		40 s		0 to 3,999 s (1 s unit)	
Manual output		—		0.0% to 100.0% (0.1% unit)	
Control period		20 s		1 to 99 s (1 s unit)	
Input shift range		—		-99.9 to 999.9 °C/°F (0.1°C/°F unit)	0.1 °C Ranges -99.9 to 999.9 °C/°F (0.1°C/°F unit) 0.01 °C Ranges -9.99 to 99.99 °C/°F (0.01°C/°F unit)
Sampling period		1 s		0.5 s	
Output	Output refresh period	1 s		0.5 s	
	Output form	NPN (TC□01) or PNP (TC□02) outputs with short-circuit protection		NPN (TC□01/TC□03) or PNP (TC□02/TC□04) outputs with short-circuit protection	
	Maximum switching capacity	100 mA, 24 VDC +10%/-15%		100 mA, 24 VDC +10%/-15%	
	Leakage current	0.3 mA max.		0.1 mA max.	
	Residual voltage	3.0 V max.		0.8 V max.	
External supply voltage		15 mA min., 24 VDC +10%/-15%		30 mA min., 24 VDC +10%/-15%	
Internal current consumption		220 mA max. at 5 VDC		190 mA max. at 5 VDC	
Heater burn-out alarm	Maximum heater current	—		50 A, single-phase AC	
	Input current monitoring accuracy	—		±5% FS ±1 digit	
	Heater burnout alarm setting	—		0.1 to 49.9 A in 0.1 A increments (See Note 1)	
	Minimum ON time for detection	—		200 ms (See Note 2)	

- Note: 1. Heater burnout detection will be disabled if the alarm is set to 0.0 A. The heater burnout alarm output will turn ON if the alarm is set to 50.0 A.  
2. If the control output is ON for less than 200 ms, heater burnout will not be detected and the heater current will not be measured.

**Temperature Ranges**

**Temperature Ranges for Thermocouples**

Input type	Code No.	°C	°F
K	0	-200 to 1300	-300 to 2300
K	1	0.0 to 500.0	0.0 to 900.0
J	2	-100 to 850	-100 to 1500
J	3	0.0 to 400.0	0.0 to 750.0
T	4	-200.0 to 400.0	-300.0 to 700.0
L	5	-100 to 850	-100 to 1500
L	6	0.0 to 400.0	0.0 to 750.0
R	7	0 to 1700	0 to 3000
S	8	0 to 1700	0 to 3000
B	9	100 to 1800	300 to 3200

**Temperature Ranges for Platinum Resistance Thermometers**

Input type	Code No.	°C	°F
Pt100	0	-200.0 to 650.0	-300.0 to 1200.0
JPt100	1	-200.0 to 650.0	-300.0 to 1200.0
Pt100	2	-20.00 to 250.00	Do not set.
JPt100	3	-20.00 to 250.00	

**Output Circuits**

CQM1-TC□01/TC□03: Sinking Outputs (NPN)

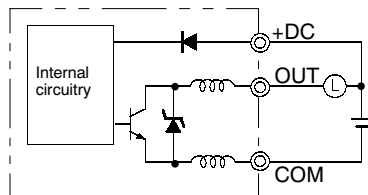

CQM1-TC□02/TC□04: Sourcing Outputs (PNP)

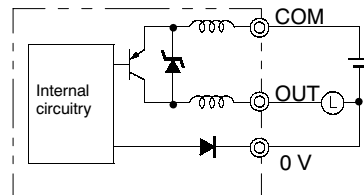

**Heater Burnout Current Detector Ratings**

Item	E54-CT1	E54-CT3
Continuous max. heater current	50 A	
Range for accurate measurement	0 to 30 A	0 to 50 A
Withstand voltage	1,000 VAC	
Shock resistance	50 Hz (Approx. 98 m/s <sup>2</sup> )	
Hole diameter	5.8 mm	12.0 mm
Weight	Approx. 11.5 g	Approx. 50 g
Accessories	None	Contactors: 2 Plugs: 2

**■ CONFIGURATION**

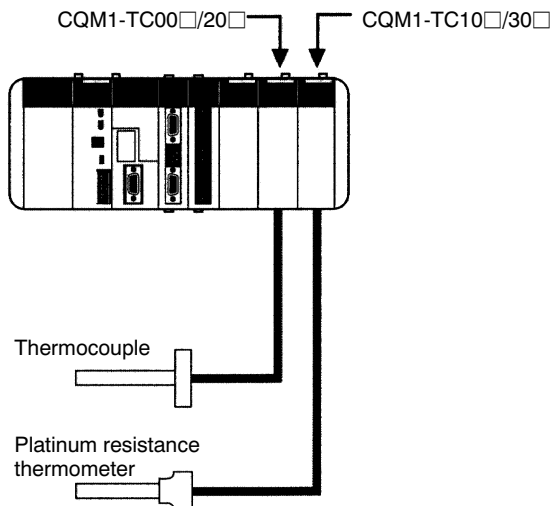

## Linear Sensor Interface Modules

Used primarily for length and distance calculations, the Linear Sensor Interface Modules measure voltage or current inputs from an Omron measurement sensor then quickly and accurately convert the analog signal to numeric data for comparative decision processing. You can also sync internal processing using external timing signals.

**CQM1-LSE01 (Standard Interface)**  
**CQM1-LSE02 (Interface with Monitor Output)**

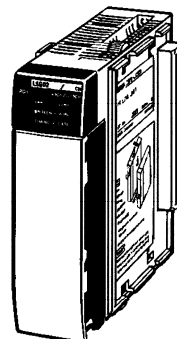

- A high-speed sampling cycle of 1 ms can be combined with high-speed external timing at 0.3 ms to easily detect high-speed changes in analog signals.
- Scaling and comparative decision processing reduces the burden on the CQM1H's CPU, achieving faster processing both in the module and for the PLC all around.
- A forced-zero function lets you easily change reference points for different workpieces.
- The monitor output allows a specified voltage to be output from the ladder-diagram program to provide analog output capability (CQM1-LSE02 only).

### ■ SPECIFICATIONS

#### General

Item		CQM1-LSE01	CQM1-LSE02
Input	No. of analog input points	1	
	Input signal range	Voltage	-9.999 to 9.999 V, -5 to 5 V, 1 to 5 V
		Current	4 to 20 mA
	Input impedance	Voltage	1 MΩ min.
Current		10 Ω	
Linearity		±0.1% FS ±1 digit max. with input sampling speed set to slow ±0.5% FS ±1 digit max. with input sampling speed set to fast	
PLC output code		Signed binary (-9999 to 9999)	
Sampling time		0.3 ms with input sampling speed set to fast and 0.6 ms with input sampling speed set to slow	
Sampling cycle		1 ms with input sampling speed set to fast and 2 ms with input sampling speed set to slow	
Arithmetic processing time		5 ms	
External control inputs		TIMING/GATE, ZERO, ZERO RESET, RESET	
Words allocated		1 input word and 1 output word	
Monitor output	Output signal	—	-9.999 V to 9.999 V
	Output linearity	—	±0.1% FS
	Output resolution	—	1/8192
	Output refresh period	—	0.5 s
	Output response time	—	0.5 s
	Allowable load resistance	—	10 kΩ min.
Insulation		Photocoupler insulation between input terminals and PLC signals and between input terminals and output terminals.	
Dielectric strength		500 VAC for 1 minute between input terminals and output terminals 1,000 VAC for 1 minute between I/O terminals and FG	
Internal current consumption		380 mA max. at 5 VDC	450 mA max. at 5 VDC
Weight		230 g max.	

**Control Input**

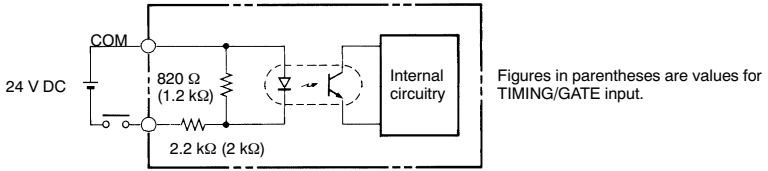
Item	Specification
Input voltage	24 VDC +10%/-15%
Input impedance	TIMING/GATE: 2 kΩ Other control output: 2.2 kΩ
Input current	TIMING/GATE: 9.2 mA typical (24 VDC) Other control output: 10.0 mA typical (24 VDC)
ON voltage	TIMING/GATE: 16.3 VDC min. Other control output: 17.1 VDC min.
OFF voltage	TIMING/GATE: 3.8 VDC max. Other control output: 3.6 VDC max.
ON/OFF response time (See note)	TIMING/GATE: 50 μs typical Other control output: 4 ms typical
Circuit configuration	

Note: The ON/OFF response time is the time required for the CPU to detect input turned ON or OFF.

**■ CONFIGURATION**

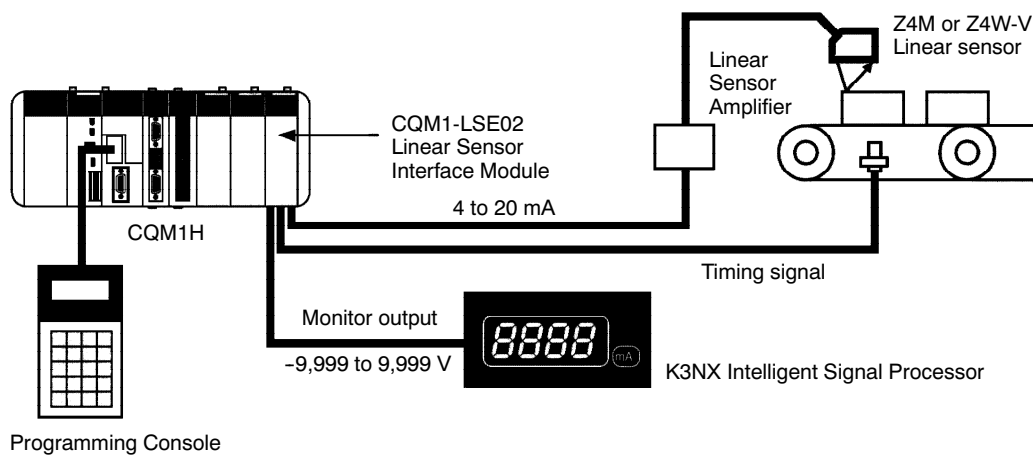

Programming Console

## Safety Relay Module

Use the Safety Relay Module to reduce the wiring time and costs and installation space for safety circuits. It can monitor the following four statuses of the safety circuit:

### CQM1-SF200

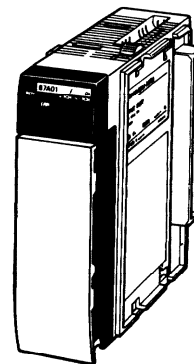

1. Safety Circuit Output Status  
Monitors if the safety circuit is operating and producing outputs.
2. Safety Circuit Power Status  
Monitors the status of the power supply to the safety circuit.
3. K1 Relay Operating Status
4. K2 Relay Operating Status  
Monitors the status of the internal relays that form the safety circuit. This helps troubleshooting safety circuit problems.

In addition to the safety circuit, the module offers general-purpose inputs for synchronization: 4 inputs and 1 common.

## ■ SPECIFICATIONS

### General

Item	Specifications	
Contact resistance (See Note 1)	100 mΩ	
Operating time (See Note 2)	300 ms max.	
Response time (See Notes 2 and 3)	10 ms max.	
Durability	Mechanical	5 million operations min. (switching frequency: 7,200 times/hour)
	Electrical	100,000 operations min. (rated load, switching frequency: 1,800 times/hour)
Error rate (P level: reference value)	1 mA at 5 VDC	
Weight	260 g max.	

- Note: 1. Measurement conditions: 1 A at 5 VDC voltage drop method  
 2. Bounce time is not included.  
 3. The response time is from when the input is turned OFF to when the main contact turns OFF.

### Safety Circuit Ratings

#### Power Supply Section

Item	Specifications
Supply voltage	24 VDC
Permissible voltage fluctuation range	-15%/+10% of supply voltage
Power consumption	1.7 W max., 24 VDC

#### Input Section

Item	Specifications
Input current	75 mA max.

#### Switching Section

Item	Specifications
Load	Resistive load (cos = φ1)
Rated load	5 A at 250 VAC
Rated switching current	5 A

### General-purpose Input Ratings

Item	Specifications
Rated input voltage	24 VDC -15%/+10%
Input impedance	4.0 kΩ
Input current	6 mA typ. (24 VDC)
ON voltage/ON current	14.4 VDC min./3 mA min.
OFF voltage/OFF current	5 VDC max./1 mA max.
ON/OFF response time	8 ms max. (selectable from 1 to 128 ms using System Setup.)
Number of circuits	4 inputs and 1 common
Number of points that turn ON simultaneously	100% simultaneously ON
Internal current consumption	50 mA max.

### Output Circuit

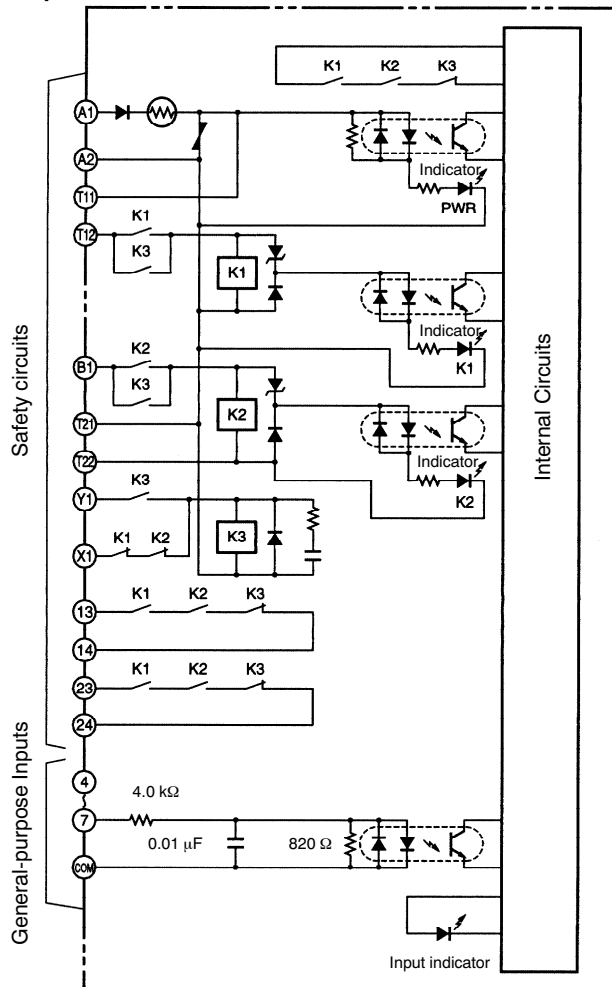

# Dimensions

Unit: mm (inch)

## OVERALL CQM1H DIMENSIONS

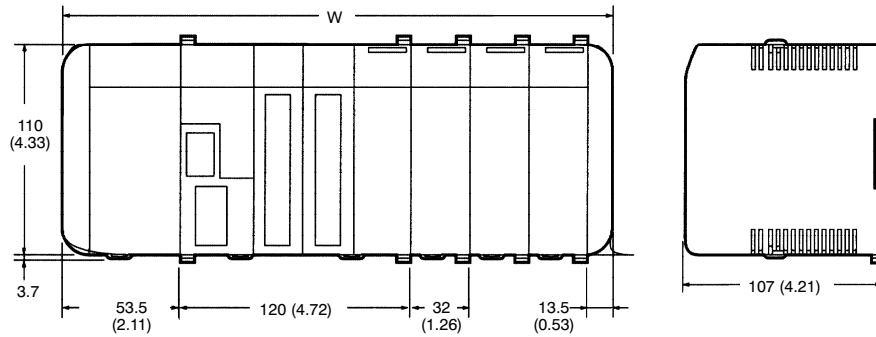

### Overall PLC Widths for Example Configurations

Number of I/O Modules	Width with PA203 Power Supply Unit	Width with PA206, PA216, or PD026 Power Supply Unit
3	283 (11.14)	315 (12.40)
4	315 (12.40)	347 (13.66)
5	347 (13.66)	379 (14.92)

### Calculating Overall PLC Width with "n" I/O Modules

Power Supply Unit	Width formula
CQM1-PA203	$32 \times n + 187$ (1.26 × n + 7.36)
CQM1-PA206	$32 \times n + 219$ (1.26 × n + 8.62)
CQM1-PA216	
CQM1-PD026	

Note: The total number of I/O Modules and Dedicated I/O Modules (n) is limited to 12 Modules (11 without a Communications Module) for the CQM1H-CPU51/61 and 11 Modules for the CQM1H-CPU11/21.

## POWER SUPPLY, CPU, COMMUNICATIONS, DEDICATED I/O, AND I/O MODULES

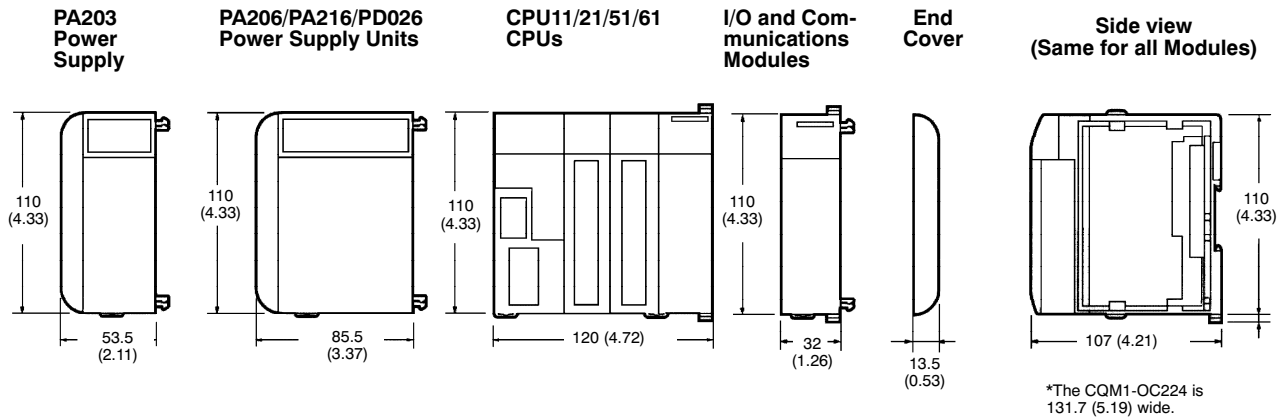

■ WEIGHT

Name	Model	Weight
Power Supply Units	CQM1-PA203	460 g max.
	CQM1-PA206	560 g max.
	CQM1-PD026	
	CQM1-PA216	
CPUs	CQM1H-CPU11	500 g max.
	CQM1H-CPU21	510 g max.
	CQM1H-CPU51	
	CQM1H-CPU61	

Name	Model	Weight
Input Units	CQM1-ID211	180 g max.
	CQM1-ID111	
	CQM1-ID212	
	CQM1-ID112	160 g max.
	CQM1-ID213	
	CQM1-ID214	
	CQM1-IA121	210 g max.
	CQM1-IA221	

Name	Model	Weight
Output Units	CQM1-OC221	200 g max.
	CQM1-OC222	230 g max.
	CQM1-OC224	270 g max.
	CQM1-OD211	200 g max.
	CQM1-OD212	180 g max.
	CQM1-OD213	160 g max.
Output Units	CQM1-OD214	210 g max.
	CQM1-OD215	240 g max.
	CQM1-OD216	210 g max.
	CQM1-OA221	240 g max.
	CQM1-OA222	

■ I/O CONTROL AND INTERFACE MODULES

CQM1H-IC101

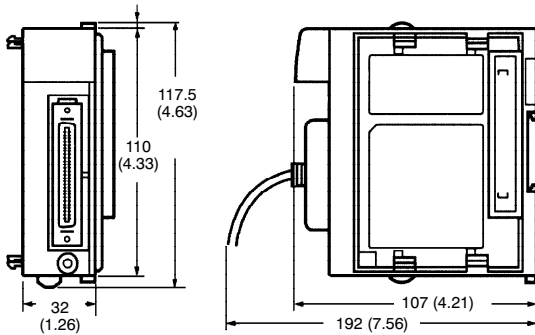

CQM1H-II101

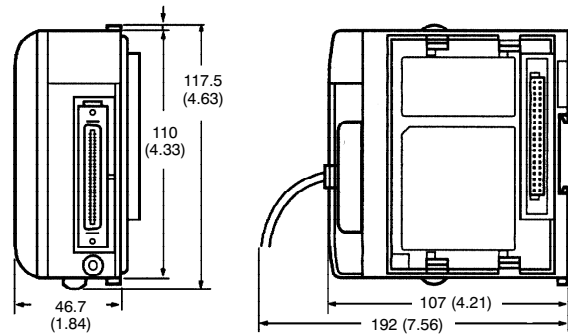

# Functions

## ■ INTERRUPT INPUT PROCESSING

All CQM1H CPUs are equipped with four inputs (IR 00000 to IR 00003) that can be used as interrupt inputs. Interrupt processing can be enabled and disabled with the INTERRUPT CONTROL - INT(89) instruction.

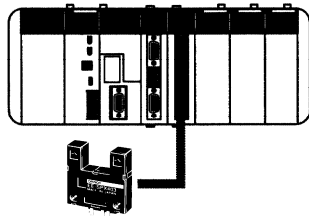

Photomicrosensor etc.

### Sample Program

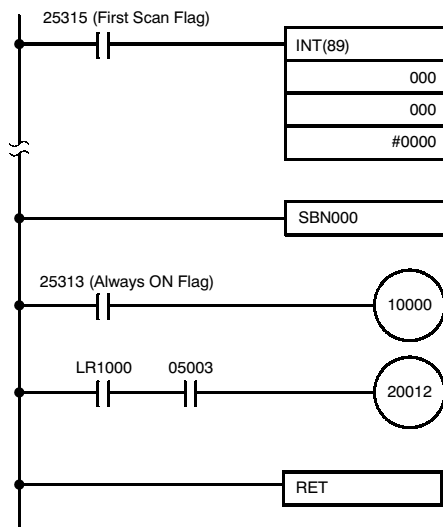

In order for interrupt input processing to be performed, the INTERRUPT CONTROL - INT(89) instruction is set so that interrupt processing is enabled when IR 00000 goes ON. When the external signal to IR 00000 goes from OFF to ON, program execution is temporarily halted, and processing moves to subroutine 00. When subroutine 000 (SBN000) is completed, its results are output immediately. The entire interrupt process, from IR 00000 going ON to the refreshing of outputs IR 10000 and IR 20012, provides high-speed I/O response that is not affected by the PLC's cycle time.

## ■ INTERVAL TIMER INTERRUPT PROCESSING

The INTERVAL TIMER - STIM(69) instruction is useful for performing repetitive processes, such as output processing, that need to be performed regularly at intervals shorter than the cycle time.

Place an STIM(69) instruction in the program to define a timer that will call and execute a subroutine at regular intervals. Up to 3 interval timers can be used.

### Sample Program

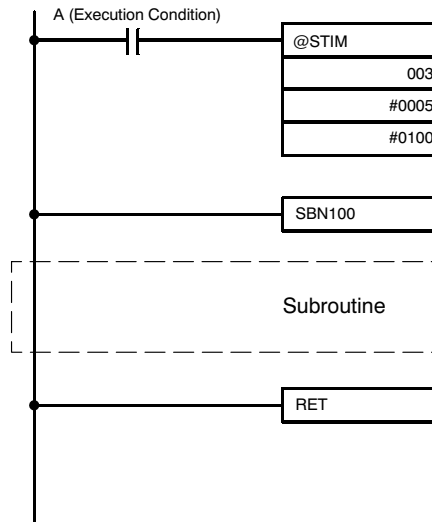

The STIM(69) instruction is used to control an interval timer. In this example, timer 0 is started in repetitive mode. As long as A (the execution condition) is ON, the main program will be halted and the interrupt routine SBN100 will be executed every 5 ms (i.e., each time the interval timer times out). Main program execution is continued when interrupt routine execution has been completed.

## INTERNAL HIGH-SPEED COUNTERS

Pulses from a rotary encoder can be input directly into 3 of the CPU's inputs (IN04, IN05, and IN06) and used as internal high-speed counter.

Pulses can be counted from 0 to 65535 in the increment mode and -32767 to 32767 in the up/down mode, with a single-phase response speed of 5 KHz and a two-phase response speed of 2.5 kHz.

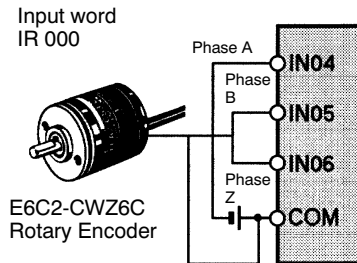

The high-speed counter's input mode is set in the DM Area's PLC Setup.

### Input Modes

Up/Down mode	Uses phase A and phase B to count up and down.
Increment mode	Uses phase A only to count up.
Normal mode	Input bit 04 to bit 06 are used as normal inputs.

### Reset Method

There are two ways to reset the counter's PV. The PV can be reset by the software reset alone or by a logical AND between the phase-Z input and the software reset.

### Comparison Conditions

Target value	Up to 16 target values can be set. The specified subroutine will be executed when the count value reaches a target value.
Zone comparison	Up to 8 zones (upper/lower limits) can be set. The specified subroutine will be executed when the count value is within a zone.

## PULSE OUTPUT: PULS(65) AND CHANGE FREQUENCY - SPED(64)

These instructions are used to control pulse outputs. They can greatly simplify tasks such as controlling stepper motors directly from the CQM1H.

### Example

In this example, the speed of a stepper motor is changed.

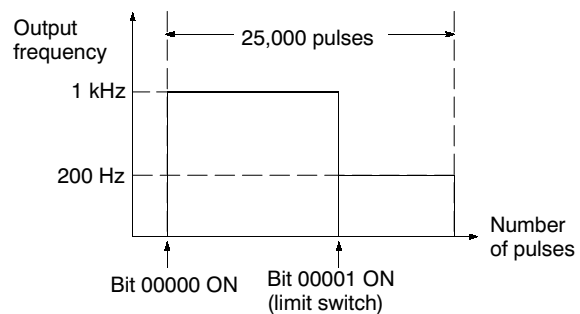
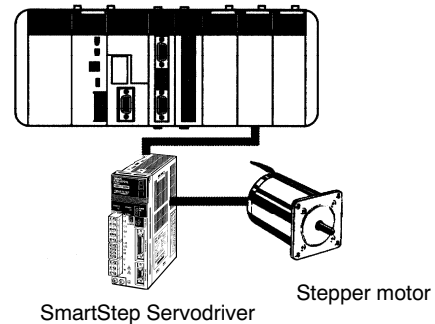

### Typical Application: Two-axis Positioning or Speed Control

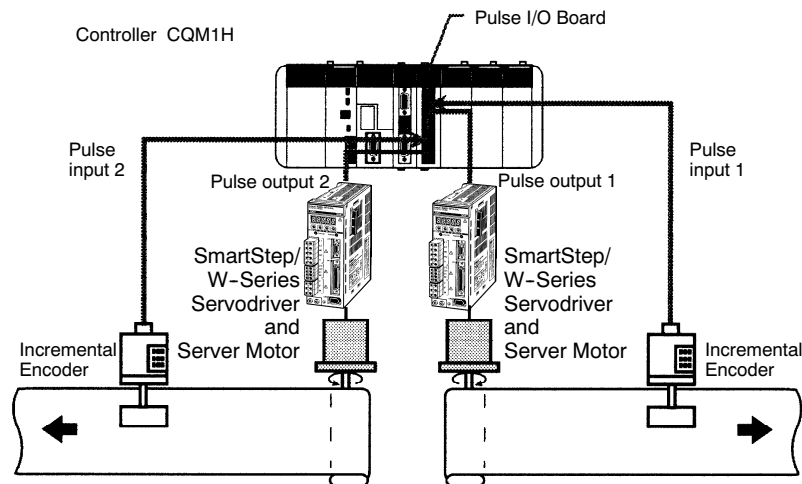

# Connections

## CONNECTIONS TO PROGRAMMING DEVICES

### Personal Computer to CPU Peripheral Port

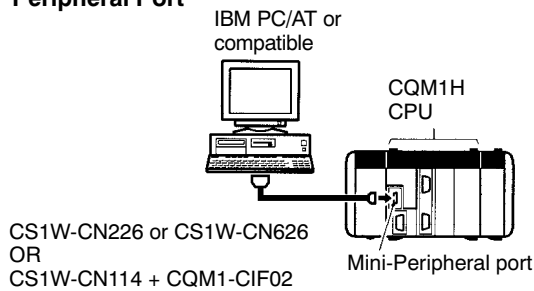

### Personal Computer to CPU RS-232C Port

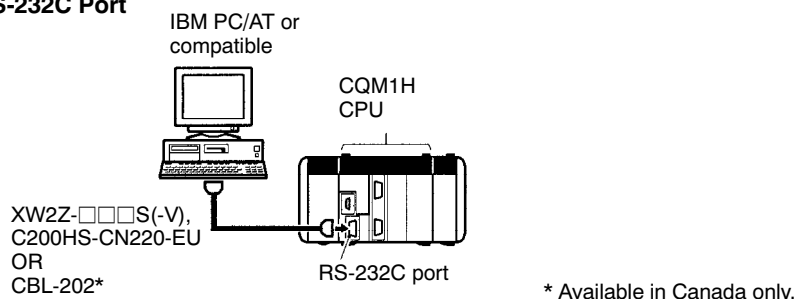

Note: You can also connect to the RS-232C port on a Serial Communications Board.

### Programming Console

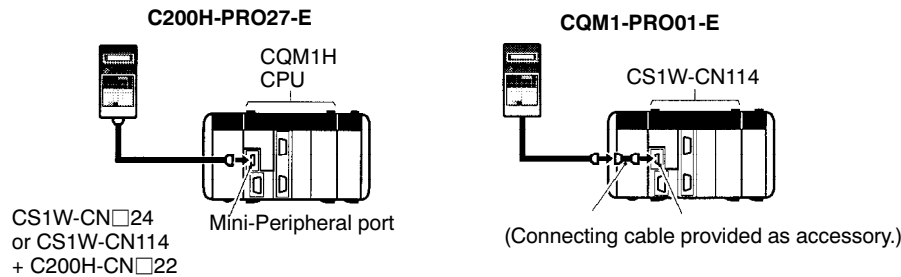

## CONNECTIONS TO OPERATOR INTERFACE TERMINAL

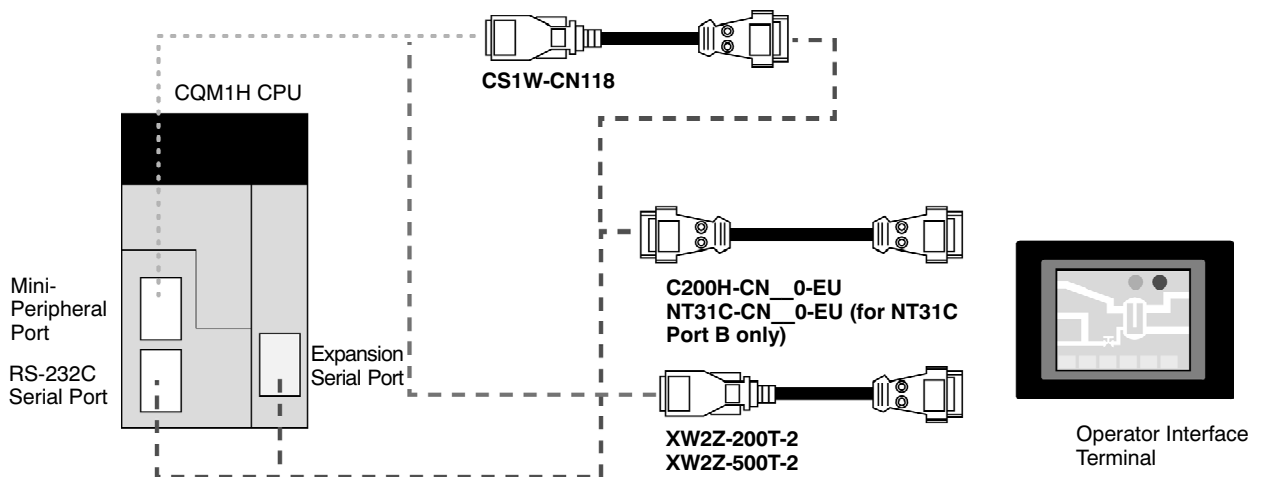

## Certain Terms and Conditions of Sale

1. **Offer; Acceptance.** These terms and conditions (these "Terms") are deemed part of all catalogs, manuals or other documents, whether electronic or in writing, relating to the sale of goods or services (collectively, the "Goods") by Omron Electronics LLC and its subsidiary companies ("Seller"). Seller hereby objects to any terms or conditions proposed in Buyer's purchase order or other documents which are inconsistent with, or in addition to, these Terms. Please contact your Omron representative to confirm any additional terms for sales from your Omron company.
2. **Prices.** All prices stated are current, subject to change without notice by Seller. Buyer agrees to pay the price in effect at time of shipment.
3. **Discounts.** Cash discounts, if any, will apply only on the net amount of invoices sent to Buyer after deducting transportation charges, taxes and duties, and will be allowed only if (i) the invoice is paid according to Seller's payment terms and (ii) Buyer has no past due amounts owing to Seller.
4. **Orders.** Seller will accept no order less than \$200 net billing.
5. **Governmental Approvals.** Buyer shall be responsible for, and shall bear all costs involved in, obtaining any government approvals required for the importation or sale of the Goods.
6. **Taxes.** All taxes, duties and other governmental charges (other than general real property and income taxes), including any interest or penalties thereon, imposed directly or indirectly on Seller or required to be collected directly or indirectly by Seller for the manufacture, production, sale, delivery, importation, consumption or use of the Goods sold hereunder (including customs duties and sales, excise, use, turnover and license taxes) shall be charged to and remitted by Buyer to Seller.
7. **Financial.** If the financial position of Buyer at any time becomes unsatisfactory to Seller, Seller reserves the right to stop shipments or require satisfactory security or payment in advance. If Buyer fails to make payment or otherwise comply with these Terms or any related agreement, Seller may (without liability and in addition to other remedies) cancel any unshipped portion of Goods sold hereunder and stop any Goods in transit until Buyer pays all amounts, including amounts payable hereunder, whether or not then due, which are owing to it by Buyer. Buyer shall in any event remain liable for all unpaid accounts.
8. **Cancellation; Etc.** Orders are not subject to rescheduling or cancellation unless Buyer indemnifies Seller fully against all costs or expenses arising in connection therewith.
9. **Force Majeure.** Seller shall not be liable for any delay or failure in delivery resulting from causes beyond its control, including earthquakes, fires, floods, strikes or other labor disputes, shortage of labor or materials, accidents to machinery, acts of sabotage, riots, delay in or lack of transportation or the requirements of any government authority.
10. **Shipping; Delivery.** Unless otherwise expressly agreed in writing by Seller:
  - a. Shipments shall be by a carrier selected by Seller;
  - b. Such carrier shall act as the agent of Buyer and delivery to such carrier shall constitute delivery to Buyer;
  - c. All sales and shipments of Goods shall be FOB shipping point (unless otherwise stated in writing by Seller), at which point title to and all risk of loss of the Goods shall pass from Seller to Buyer, provided that Seller shall retain a security interest in the Goods until the full purchase price is paid by Buyer;
  - d. Delivery and shipping dates are estimates only.
  - e. Seller will package Goods as it deems proper for protection against normal handling and extra charges apply to special conditions.
11. **Claims.** Any claim by Buyer against Seller for shortage or damage to the Goods occurring before delivery to the carrier must be presented in writing to Seller within 30 days of receipt of shipment and include the original transportation bill signed by the carrier noting that the carrier received the Goods from Seller in the condition claimed.
12. **Warranties.** (a) **Exclusive Warranty.** Seller's exclusive warranty is that the Goods will be free from defects in materials and workmanship for a period of twelve months from the date of sale by Seller (or such other period expressed in writing by Seller). Seller disclaims all other warranties, express or implied. (b) **Limitations.** SELLER MAKES NO WARRANTY OR REPRESENTATION, EXPRESS OR IMPLIED, ABOUT NON-INFRINGEMENT, MERCHANTABILITY OR FITNESS FOR A PARTICULAR PURPOSE OF THE GOODS. BUYER ACKNOWLEDGES THAT IT ALONE HAS DETERMINED THAT THE GOODS WILL SUITABLY MEET THE REQUIREMENTS OF THEIR INTENDED USE. Seller further disclaims all warranties and responsibility of any type for claims or expenses based on infringement by the Goods or otherwise of any intellectual property right. (c) **Buyer Remedy.** Seller's sole obligation hereunder shall be to replace (in the form originally shipped with Buyer responsible for labor charges for removal or replacement thereof) the non-complying Good or, at Seller's election, to repay or credit Buyer an amount equal to the purchase price of the Good; provided that in no event shall Seller be responsible for warranty, repair, indemnity or any other claims or expenses regarding the Goods unless Seller's analysis confirms that the Goods were properly handled, stored, installed and maintained and not subject to contamination, abuse, misuse or inappropriate modification. Return of any goods by Buyer must be approved in writing by Seller before shipment. Seller shall not be liable for the suitability or unsuitability or the results from the use of Goods in combination with any electrical or electronic components, circuits, system assemblies or any other materials or substances or environments. Any advice, recommendations or information given orally or in writing, are not to be construed as an amendment or addition to the above warranty.
13. **Damage Limits; Etc.** SELLER SHALL NOT BE LIABLE FOR SPECIAL, INDIRECT OR CONSEQUENTIAL DAMAGES, LOSS OF PROFITS OR PRODUCTION OR COMMERCIAL LOSS IN ANY WAY CONNECTED WITH THE GOODS, WHETHER SUCH CLAIM IS BASED IN CONTRACT, WARRANTY, NEGLIGENCE OR STRICT LIABILITY. Further, in no event shall liability of Seller exceed the individual price of the Good on which liability is asserted.
14. **Indemnities.** Buyer shall indemnify and hold harmless Seller, its affiliates and its employees from and against all liabilities, losses, claims, costs and expenses (including attorney's fees and expenses) related to any claim, investigation, litigation or proceeding (whether or not Seller is a party) which arises or is alleged to arise from Buyer's acts or omissions under these Terms or in any way with respect to the Goods. Without limiting the foregoing, Buyer (at its own expense) shall indemnify and hold harmless Seller and defend or settle any action brought against Seller to the extent that it is based on a claim that any Good made to Buyer specifications infringed intellectual property rights of another party.
15. **Property; Confidentiality.** The intellectual property embodied in the Goods is the exclusive property of Seller and its affiliates and Buyer shall not attempt to duplicate it in any way without the written permission of Seller. Notwithstanding any charges to Buyer for engineering or tooling, all engineering and tooling shall remain the exclusive property of Seller. All information and materials supplied by Seller to Buyer relating to the Goods are confidential and proprietary, and Buyer shall limit distribution thereof to its trusted employees and strictly prevent disclosure to any third party.
16. **Miscellaneous.** (a) **Waiver.** No failure or delay by Seller in exercising any right and no course of dealing between Buyer and Seller shall operate as a waiver of rights by Seller. (b) **Assignment.** Buyer may not assign its rights hereunder without Seller's written consent. (c) **Amendment.** These Terms constitute the entire agreement between Buyer and Seller relating to the Goods, and no provision may be changed or waived unless in writing signed by the parties. (d) **Severability.** If any provision hereof is rendered ineffective or invalid, such provision shall not invalidate any other provision. (e) **Setoff.** Buyer shall have no right to set off any amounts against the amount owing in respect of this invoice. (f) As used herein, "including" means "including without limitation".

## Certain Precautions on Specifications and Use

1. **Suitability of Use.** Seller shall not be responsible for conformity with any standards, codes or regulations which apply to the combination of the Good in the Buyer's application or use of the Good. At Buyer's request, Seller will provide applicable third party certification documents identifying ratings and limitations of use which apply to the Good. This information by itself is not sufficient for a complete determination of the suitability of the Good in combination with the end product, machine, system, or other application or use. The following are some examples of applications for which particular attention must be given. This is not intended to be an exhaustive list of all possible uses of this Good, nor is it intended to imply that the uses listed may be suitable for this Good:
  - (i) Outdoor use, uses involving potential chemical contamination or electrical interference, or conditions or uses not described in this document.
  - (ii) Energy control systems, combustion systems, railroad systems, aviation systems, medical equipment, amusement machines, vehicles, safety equipment, and installations subject to separate industry or government regulations.
  - (iii) Systems, machines and equipment that could present a risk to life or property. Please know and observe all prohibitions of use applicable to this Good.
2. **Programmable Products.** Seller shall not be responsible for the user's programming of a programmable Good, or any consequence thereof.
3. **Performance Data.** Performance data given in this catalog is provided as a guide for the user in determining suitability and does not constitute a warranty. It may represent the result of Seller's test conditions, and the user must correlate it to actual application requirements. Actual performance is subject to the Seller's Warranty and Limitations of Liability.
4. **Change in Specifications.** Product specifications and accessories may be changed at any time based on improvements and other reasons. It is our practice to change part numbers when published ratings or features are changed, or when significant construction changes are made. However, some specifications of the Good may be changed without any notice. When in doubt, special part numbers may be assigned to fix or establish key specifications for your application. Please consult with your Seller's representative at any time to confirm actual specifications of purchased Good.
5. **Errors and Omissions.** The information in this catalog has been carefully checked and is believed to be accurate; however, no responsibility is assumed for clerical, typographical or proofreading errors, or omissions.

NEVER USE THE PRODUCT FOR AN APPLICATION INVOLVING SERIOUS RISK TO LIFE OR PROPERTY WITHOUT ENSURING THAT THE SYSTEM AS A WHOLE HAS BEEN DESIGNED TO ADDRESS THE RISKS, AND THAT THE SELLER'S PRODUCT IS PROPERLY RATED AND INSTALLED FOR THE INTENDED USE WITHIN THE OVERALL EQUIPMENT OR SYSTEM.

Complete "Terms and Conditions of Sale" for product purchase and use are on Omron's website at [www.omron.com/oei](http://www.omron.com/oei) – under the "About Us" tab, in the Legal Matters section.

**ALL DIMENSIONS SHOWN ARE IN MILLIMETERS.**

To convert millimeters into inches, multiply by 0.03937. To convert grams into ounces, multiply by 0.03527.

---

**OMRON**<sup>®</sup>**OMRON ELECTRONICS LLC**

One Commerce Drive  
Schaumburg, IL 60173

**847-843-7900**

For US technical support or other inquiries:

**800-556-6766****OMRON CANADA, INC.**

885 Milner Avenue  
Toronto, Ontario M1B 5V8

**416-286-6465****OMRON ON-LINE**

Global - <http://www.omron.com>

USA - <http://www.omron.com/oei>

Canada - <http://www.omron.ca>